



STERLING®



SENIOR®

**HIGH CAPACITY
HYDRONIC PERIMETER
BASEBOARD RADIATION**



MADE IN THE USA

Across Europe and America, Hydronic Heating Is the Proven Standard for Comfort and Economy.



SENIOR hydronic baseboard radiation offers all these advantages with high capacity output and Sterling's proven reliability, performance, and distinctive beauty.

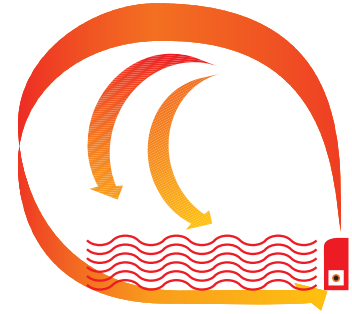

- *Hydronic heating doesn't dry out the inside air like forced air systems.*
- *Gentle convection warms the full length of cold walls and windows.*
- *Rooms are easily zoned for individual control, resulting in lower fuel bills.*
- *A dedicated heating system has none of the compromises of a combined heating/cooling system.*

Beautiful Design

Sterling SENIOR baseboard radiation is the big brother of our famous KOM-PAK baseboard, sharing the same beautiful enclosure design and convenient installation. The design offers the decorating flexibility homeowners prefer. Smooth, radius-formed end covers merge and match with the unit's sleek flowing lines. Enclosures are prepainted in baked enamel Classic White finish to complement any decor.

High Capacity

Unusually low in height for a baseboard with such high heating capacity, SENIOR is ideally suited for installation in residential homes, apartments, and light commercial buildings. SENIOR's high capacity design is perfect for rooms with high heat loss but little available wall space, such as bathrooms, sun porches, and kitchens. *(For a totally integrated hydronic heating system, also use Sterling KOM-PAK in living areas where average heat losses occur.)* Sterling SENIOR baseboard radiation provides extra comfort with the quality you expect from Sterling.



Simple Installation

SENIOR baseboards provide the flexible installation options contractors demand. The heavy gauge brackets simply snap in place, exactly where you want them. Telescoping fill-in sections eliminate cutting and waste, and a flared tube at one end of the element eliminates couplings. Enclosures are sized to accommodate a return tube when needed.

Accessories snap into place with no sheet metal screws ever required. System components give the unit structural strength, complete rigidity, and freedom from warping.

Baseboards are stocked in 8', 7', 6', 5', 4', 3', and 2' lengths and packaged to suit your needs. Splice plates are provided with 8', 6', and 5' assembled lengths. Telescoping sections come in 14" lengths.

Quiet Operation

The sturdy SENIOR element uses Sterling's "Open Box" fin design that prevents fin edges from contacting one another. The boxed and serrated aluminum fins increase the radiating surface while directing and increasing convection. Sterling's exclusive Silent Glide Shoe, allows the heating element to expand and contract smoothly for silent operation.

Superior Performance

Specially designed dampers allow fingertip control of temperature and air flow direction in each room.

Accessories

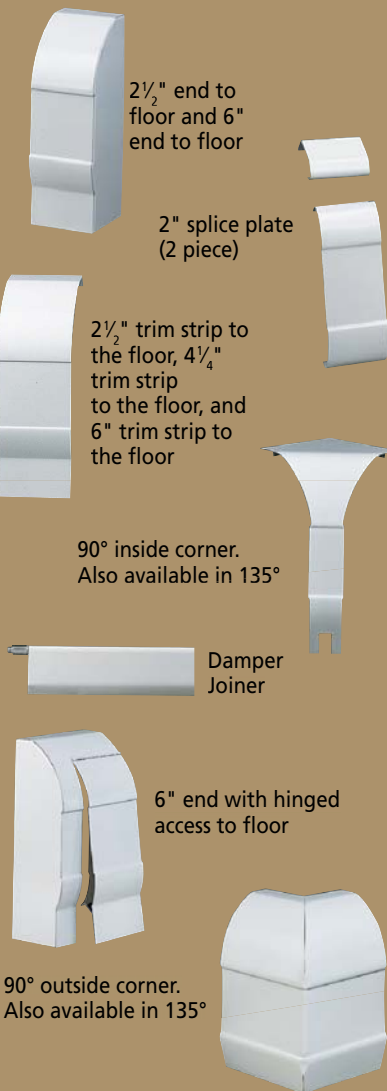

Accessory Packages

Catalog Number	Type of Accessory
White	
WQ-3AL	2 1/2" End Cap (to Floor) Left Hand
WQ-3AR	2 1/2" End Cap (to Floor) Right Hand
WQ-4L	6" End Cap (to Floor) Left Hand
WQ-4R	6" End Cap (to Floor) Right Hand
WQ-5	Inside Corner 90°
WQ-5B	Inside Corner 135°
WQ-6	Outside Corner 90°
WQ-6B	135° Outside Corner
Q-7S	Element Slide Shoe
Q-7D	Damper Carrier
WQ-7	Bracket, Slide Shoe & Damper Carrier
WQ-8L	6" End Cap w/Hinged Access (to Floor) L.H.
WQ-8R	6" End Cap w/Hinged Access (to Floor) R.H.
WQ-9A	2 1/2" Trim Strip (to Floor)
WQ-9B	6" Wall Trim
WQ-10	14" Fill-In Section (Telescoping, One Piece)
WQ-11	Return Pipe Hanger (Above Element)
WQ-12	Damper Joiner
WQ-13	Adj. Hanger for Pipe Support (to Continue Element Piping)
WQ-14	Splice Plate (Std. 2 Piece)

Ratings

Ratings are based on finned length. Finned length is 4" shorter than element length. The use of ratings at 4 G.P.M. is limited to installations (usually loop) where the flow rate is 4 G.P.M. or greater. When the flow rate is not known the standard flow rate of 1 G.P.M. must be used.

The open-box-fin design of the Sterling Senior ¾" and 1" elements make them much more efficient than conventional elements, thus effecting a corresponding economy in the amount of radiation required for the job. All Senior elements are unpainted.

Element — 2¾" x 2½" Fin	*Water Rate G.P.M.	Average Temperature °F-Forced Hot Water — B.T.U. Per Hour Linear Foot of Finned Length							
		150	160	170	180	190	200	210	220
SR-¾-60, ¾" Tube (Cu.) 60 Fins (.011)/Ft.	1	470	550	640	720	810	890	970	1060
	4	500	580	680	760	860	940	1030	1120
SR-1-55, 1" Tube (Cu.) 55 Fins (.011)/Ft.	1	460	540	620	700	780	850	930	1010
	4	490	570	660	740	820	900	980	1070
Element — 2¾" x 3¾" Fin†									
1¼" Tube (Cu.) 50 Fins (.020)/Ft. R08	1	510	590	670	750	850	920	1010	1110
	4	540	620	710	790	890	980	1070	1180
1" IPS, 2¾" x 3¾" 40 Fins (.024)/Ft. R11	1	435	515	590	665	755	835	920	1015
	4	465	545	630	710	805	885	980	1080
1¼ IPS, 2¾" x 3¾" 40 Fins (.024)/Ft. R14	1	410	485	560	630	715	785	870	960
	4	435	515	590	665	755	835	920	1015

Requires supply tube hanger (Q13) one per bracket.

Details and Dimensions

Tube Size	A		B	C
	Min.	Max.		
¾" Cu.	3¼"	4⅝"	6 ¹¹ / ₁₆ "	3½"
1" Cu.	3⅝"	4¾"	6 ¹³ / ₁₆ "	3½"
1¼" Cu./Stl.	3½"	4⅞"	6 ¹⁵ / ₁₆ "	4⅞" †

*WATER FLOW CORRECTION FACTORS					
LB/HR	G.P.M.	Factor	Pressure Drop – Millinches Per Ft. Copper Element Tube Size		
			¾"	1"	1¼"
500	1.0	1.000	47	13	6
750	1.5	1.016	96	26	12
1000	2.0	1.028	157	43	20
1250	2.5	1.038	230	63	28
1500	3.0	1.045	320	87	39
1750	3.5	1.051	420	114	50
2000	4.0	1.057	525	145	63
2250	4.5	1.062	650	178	77
2500	5.0	1.067	775	216	93
3000	6.0	1.074	1060	290	124

If the calculated water flow rate through a baseboard unit in a completely designed hot water heating system is greater than the standard flow rate (500 lb/hr), the rating of that unit may be increased by multiplying the standard water rating at 500 lb/hr by the factor shown for the calculated flow rate.

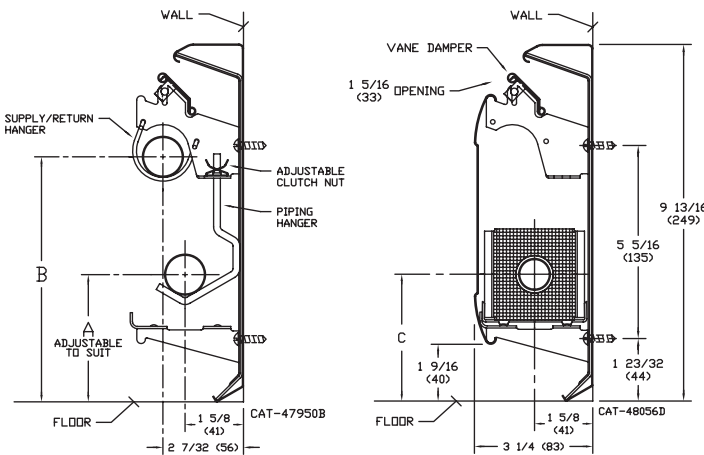

Assembly for:
R08, R11, R14 Elem.

Note: Dimension in "()"
are shown in millimeters.



260 North Elm Street • Westfield, MA 01085
Telephone (413) 564-5545 • FAX (413) 572-3764
www.sterlingheat.com

