



RESIDENTIAL  
HYDRONIC  
BASEBOARD  
RADIATION

**Petite** 



# Petite<sup>7</sup>

Petite 7 hot water baseboard radiation offers the decorating advantages homeowners want most . . . the ease of assembly installing contractors demand . . . plus the performance excellence that assures long-term customer satisfaction.

## **Low-Profile Design**

Prepainted in Classic White and less than 7" in height, Petite 7 blends beautifully in any home or apartment, from traditional to contemporary. Its wall-hugging design and smooth contours allow complete freedom in placement of furniture and window treatments.

## **Simple Installation**

Petite 7 promises effortless installation with easy-open packages, completely pre-assembled panels and snap-on accessories. The exclusive Petite 7 lay-back front panel snaps up out of the way after positioning. This reduces risk of damage and allows easy access during and after installation. A wide range of snap-on, die-formed accessories create a smooth, finished look without screws.

## **Superior Performance**

Petite 7 is more than a beautiful baseboard. 3/4" copper tubing heating element offers precise heating comfort with maximum efficiency. Full-collared, all-aluminum fins eliminate expansion noise.



## Installs and Operates Smoothly and Efficiently

### Classic White Styling

Versatile Classic White pre-painted finish is preferred by homeowners and decorators alike. Or, it can be repainted with any oil-base paint. Slim, unobtrusive lines add to its overall appeal.

### Accessories

Petite 7 offers a complete range of snap-on accessories for a flawless finish in minutes. End caps with tabs for a tight fit.

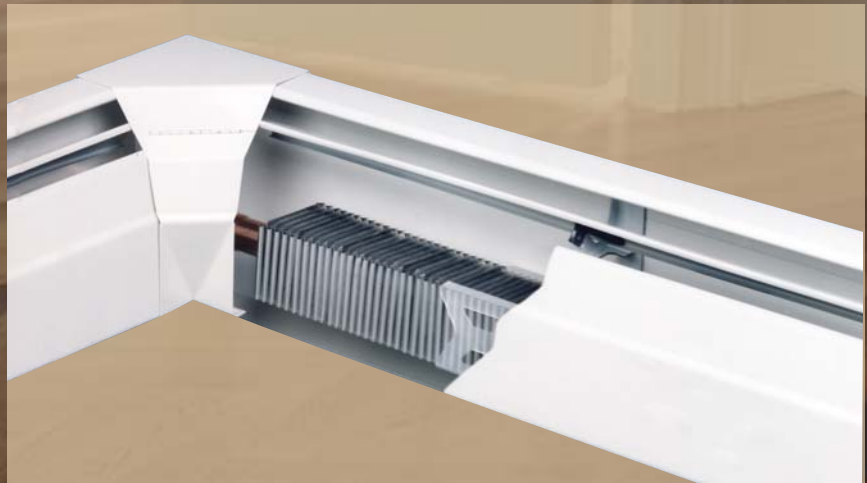

### Damper Temperature Control

Allows fingertip control of room-to-room temperature and air flow direction. Heat-treated spring steel damper hinge provides maximum wear and damper pivot security.

### Wall Attachment Guides

Inscribed along the full horizontal length of the back panel. Simply find the stud and affix the screws. No need to shift the baseboard to special screw locations.

### Exclusive Lay-Back Panel

Front panel swings up and locks into special hanger bracket for total accessibility during installation, maintenance and cleaning.

### Assembled Hanger Bracket

Snap-in tension lock requires no screws or bolts. Shipped factory-assembled, or may be repositioned and locked anywhere on back panel. Heavy steel spring tension design ensures durability and holding action. Includes provision for return tube hanger.

### Durable Plastic Glide

Snaps securely onto element fin without wrapping around or buttoning down. Plastic glide rails promote quiet floating action during expansion and contraction. Glide may be positioned anywhere on back panel to isolate an element when required.

### One-Piece Design

One-piece front and back panel design installs quickly and easily. Simply position unit against wall, swing up lay-back panel and screw to studs. Contouring strengthens front panel while enhancing streamlined appearance.

Available in 2', 3', 4', 5', 6', 7' and 8' lengths. 100% fin contact provides steady, even heating. One end of tubing is swaged for quick joining and sweating. Also available with 1/2" copper tubing.

## Petite 7® Accessories



3" End Cover



2" Solid Joiner



4" Wall Trim



Splicer Strip



Hinged Inside Corner



4" Hinged Valve End Cover



Outside Corner

## PETITE 7® BASEBOARD RATINGS

AVERAGE HOT WATER TEMPERATURE OF - BTU/HR/LIN. FT										
Model	GPM	120°	130°	140°	150°	160°	170°	180°	190°	200°
P77A 3/4"	4	225	285	350	410	480	540	600	670	730
	1	215	270	330	390	450	510	570	630	690
P75A 1/2"	4	235	290	355	420	490	560	620	690	760
	1	220	275	335	400	460	530	590	650	720

## RATINGS AND PRESSURE DROPS AT VARIOUS FLOW RATES

GPM	1.0	2.0	3.0	4.0	5.0	6.0
Factor to Obtain Rating at Given Flow (see note 5)	1.000	1.028	1.045	1.057	1.067	1.074
P5E, Element – P.D. Millinches Per Ft.	260	850	1,730	2,880	4,300	5,900
P7E, Element – P.D. Millinches Per Ft.	47	157	320	525	775	1,060

- NOTES**
- Hot water ratings shown are based on an active length of 7.75 ft. The total length is 3 inches longer or 8.0 feet
  - Hot water capacities are obtained by actual test at 500 lbs./hr. water flow rate to which 15% has been added in accordance with testing procedures.
  - The heating element P7E is 3/4" nominal diameter copper tubing with unpainted aluminum fins 2" x 2 1/2" x .010", 51.8 fins per foot.
  - The heating element P5E is 1/2" nominal diameter copper tubing with unpainted aluminum fins 2 1/8" x 2 1/8" x .008", 55.5 - 57.1 fins per foot.
  - If the calculated water flow rate through a baseboard unit in a completely designed hot water heating system is greater than the standard flow rate (500 lb/hr), the rating of that unit may be increased by multiplying the standard rating at 500 lb/hr by the factor shown for the calculated flow rate.
  - Ratings at 4 gpm should not be used unless the flow rate is known to be equal to or greater than 4 gpm. Where the flow rate is unknown, rating at 1 gpm 500 lb./hr. must be used.

## PETITE 7® PACKAGES

Assembled Baseboard	Element Size	Carton No.* (Specify)
<b>SINGLE PACK</b> Front Panel, Back Panel, Damper with Pivot, Hanger Brackets, and Heating Element with Plastic Glides all assembled and shipped in a single carton, 2" Splicer Set included with each 5', 6', and 8' length.	3/4"	P77A-10
		P77A-8
		P77A-7
		P77A-6
		P77A-5
		P77A-4
		P77A-3
	P77A-2	
	1/2"	P75A-10
		P75A-8
		P75A-7
		P75A-6
		P75A-5
		P75A-4
P75A-3		
P75A-2		

Element Only	Element Size	Carton No.* (Specify)
<b>FOUR PACK</b> Each carton contains four Elements plus necessary Plastic Glides.	3/4"	7ME4-8 7ME4-7 7ME4-6 7ME4-5 7ME4-4 7ME4-3 7ME4-2
The heating element 7E is 3/4" nominal diameter copper tubing with unpainted aluminum fins 2" x 2 1/2" x .010", 51.8 fins per foot.		
<b>FOUR PACK</b> Each carton contains four Elements plus necessary Plastic Glides.	1/2"	5ME4-8 5ME4-7 5ME4-6 5ME4-5 5ME4-4 5ME4-3 5ME4-2
The heating element 5E is 1/2" nominal diameter copper tubing with unpainted aluminum fins 2 1/8" x 2 1/8" x .008", 55.5 - 57.1 fins per foot.		

## DIMENSIONAL DATA

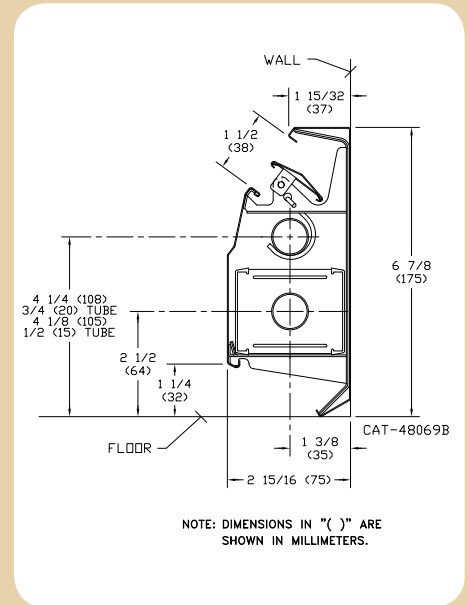

Description	Catalog No.	Master Carton Qty.
3" End Cover, Right Hand	P-105	10
3" End Cover, Left Hand	P-106	10
4" Hinged Valve End Cover, Right Hand	P-83	7
4" Hinged Valve End Cover, Left Hand	P-84	7
90° Hinged Inside Corner	P-89	10
135° Hinged Inside Corner	P-90	10
90° Outside Corner	P-93	10
135° Outside Corner	P-94	10
2" Solid Joiner	P-107	10
4" Wall Trim	P-95	10
2" Splicer Strip (3 pieces)	P-96	10 Sets
7" Splicer Strip (3 pieces)	P-97	10 Sets
14" Splicer Strip (3 pieces)	P-98	As Ordered
Hanger Bracket, Plastic Glide & Damper Pivot	P-104	25
Supply Tubing Support Hanger	P-102	50
Return Tubing Support Hanger	P-103	50
Touch-Up Spray Paint	P-TUP	6
Plastic Glide Set	P-101	12
Damper Pivot	P-108	25

Enclosure Only	Packaging	Carton No.* (Specify)
<b>SINGLE PACK</b> Front Panel, Back Panel, Damper with Pivot, Hanger Brackets all assembled and shipped in a single carton, 2" Splicer Set included with each 5', 6', and 8' length.	Assembled	P7C-10 P7C-8 P7C-7 P7C-6 P7C-5 P7C-4 P7C-3 P7C-2

\*Last digit of carton number designates length in carton.



260 North Elm Street, Westfield, MA 01085, (413) 564-5545, FAX (413) 572-3764  
7555 Tranmere Drive, Mississauga, Ontario, L5S 1L4, (905) 670-5888, FAX (905) 670-5782

www.sterlingheat.com



PB-11